



Experis<sup>®</sup>  
ManpowerGroup

# Turn-Key Activities & Competence Centers

# ManpowerGroup Worldwide Overview



70 Anni d'esperienza nelle Global Workforce Solutions



Most Trusted Brand nel settore



Fatturato  
**\$21 billion**



**88%**  
del fatturato generato fuori dagli U.S.A.



80 Nazioni



28,000  
dipendenti



2,500  
Uffici

- Ogni giorno impiega **600,000+** persone
- Connette **milioni** di persone con le aziende, ogni giorno



Strong and Connected Brands



ManpowerGroup®



Manpower®



Experis®  
ManpowerGroup



Talent  
Solutions  
ManpowerGroup®

# MANPOWERGROUP - OVERVIEW



10 Uffici in Italia  
4 Sedi Experis Academy  
3 Labs  
> 100 Recruiting  
> 500 Technical Consulting and Engineers by our Clients  
> 28M Annual Turnover



Accelerating BUSINESS GROWTH depends on access to the RIGHT EXPERTISE  
It takes a new and DIFFERENT APPROACH to deliver the RIGHT TALENT.

# DOVE INTERVENIAMO

Interveniamo in tutte le aree del business che possono avere necessità di supporto tecnico-ingegneristico:

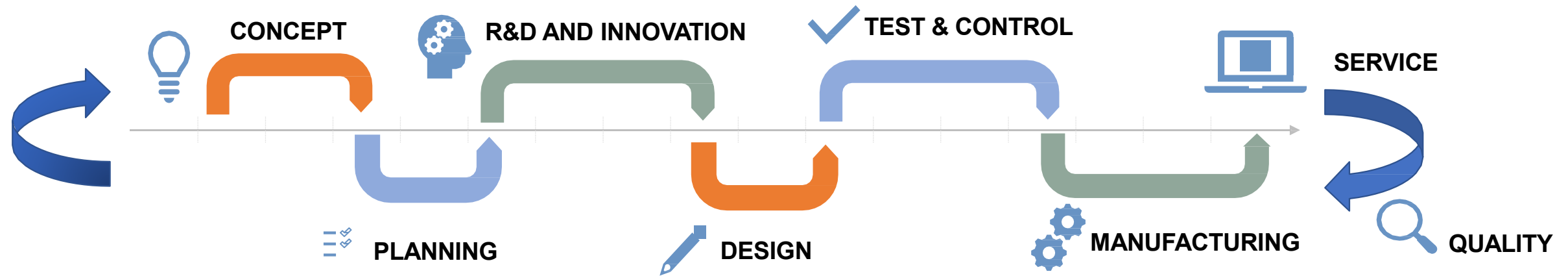

Siamo presenti come **TECHNICAL PARTNER** in tutti i mercati ad elevato contenuto tecnologico:



# Delivery Model

Il nostro Delivery Model si basa su una proposta di approcci flessibili per una collaborazione più funzionale al progetto:



## CONSULTING

Competenze specialistiche e *supporto tecnico* per realizzare i progetti del cliente ed integrare il team del cliente.



## COMPETENCE CENTER

Team di competenze che operano sulla base di *KPI* o *SLA* relativi alla loro gestione o su base workpackages.



## TURN KEY Project

Gestione di progetti «*Chiavi in mano*» con commitment su Deliverables, Pianificazione e Budget.



## HR Career Provider

Pianificazione di un *career path* per i nostri lavoratori unitamente alla sensibilizzazione di un piano di *welfare*.

**FLESSIBILITA' – VELOCITA' – EFFICIENZA – FIDELIZZAZIONE RISORSE**

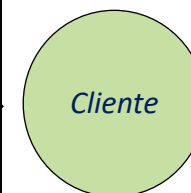

## Certificazioni

Il sistema qualità di Experis è conforme ai requisiti della norma  
**UNI EN9100:2018**

*Erogazione di servizi professionali per la progettazione nel settore aerospaziale*

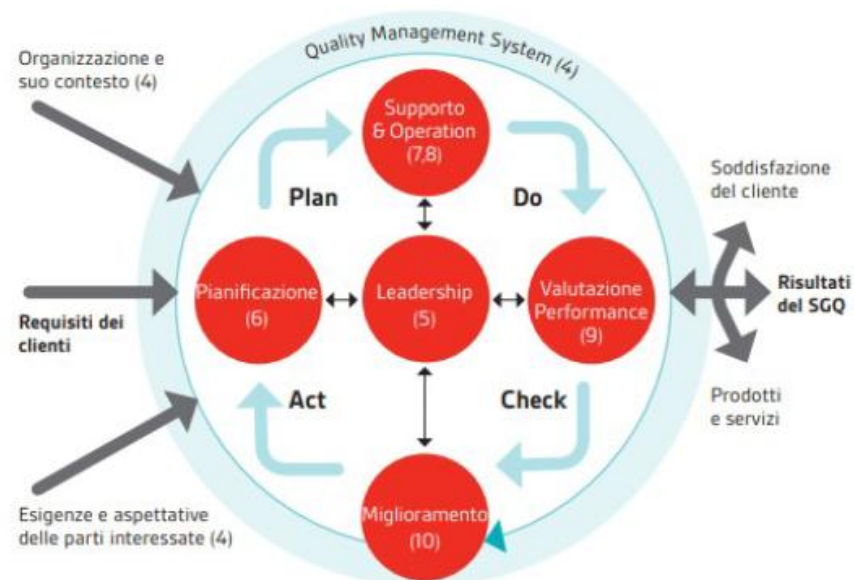



Experis<sup>®</sup>  
ManpowerGroup

# Electronics Competence Center

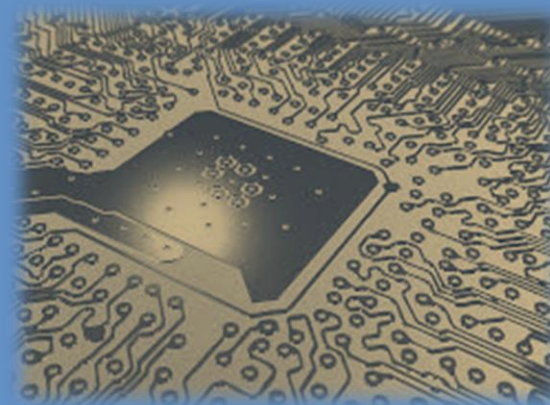

## OBIETTIVI

Attraverso questa struttura **Experis** è in grado di proporsi come partner per la **Sviluppo di SW, FW ed HW e per la creazione di prototipi ed il supporto alla produzione di serie.**

## ATTIVITA'

- Design e sviluppo HW (**Prototipazione di schede elettroniche e supporto alla produzione**)
- Design e sviluppo FW per sistemi embedded (**FPGA, BSPs**)
- Design e sviluppo **Sistemi di comando e controllo**
- Design e sviluppo di **banchi di test** (automatici e manuali)
- **Validazione, Verifica e Test SW** con il rispetto standard RTCA/DO-178C, MIL, IEC, CENELEC EN50128



SOFTWARE &  
HARDWARE DESIGN



SYSTEM  
DESIGN

# Electronic Solution

Experis Tech supporta i suoi clienti durante l'intero ciclo di vita del prodotto HW, partendo dalla definizione dei requisiti di alto livello forniti dal cliente, fino alla realizzazione di prototipi HW e meccanici.

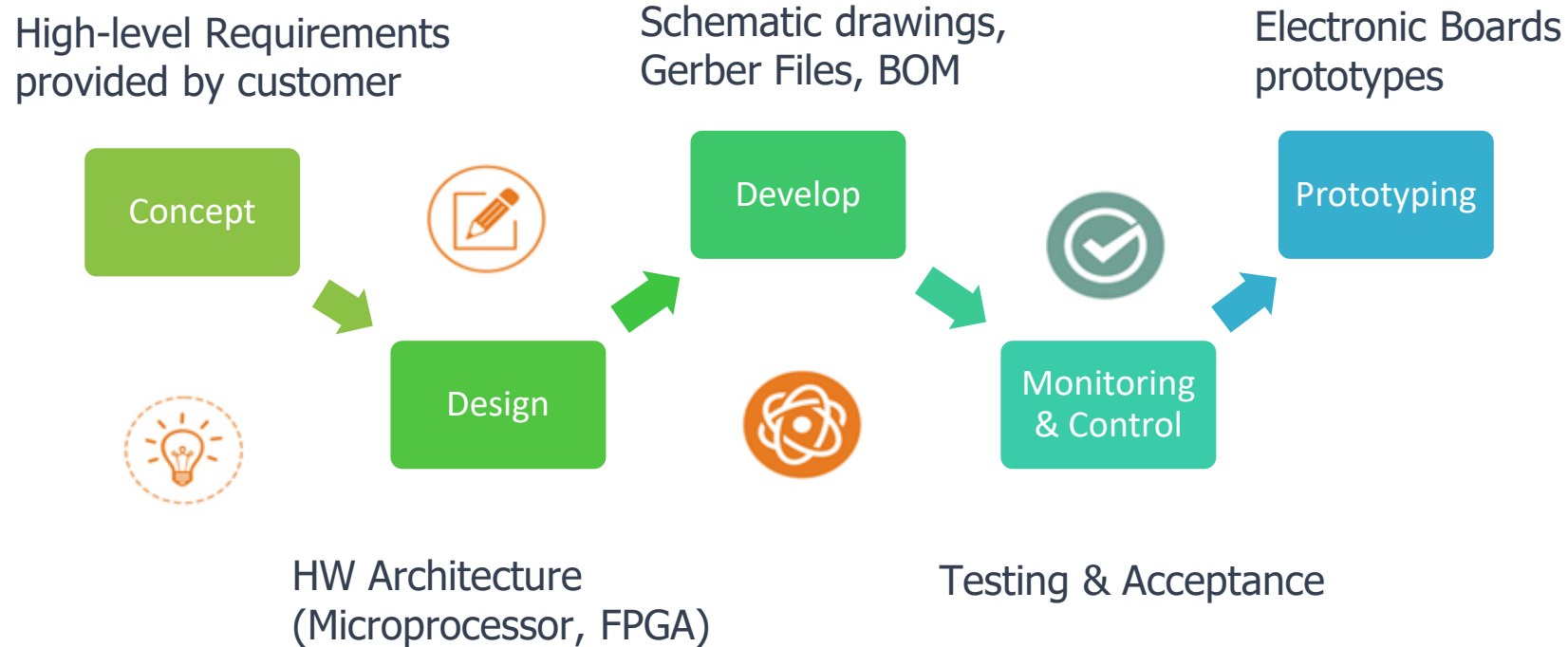



Experis<sup>®</sup>  
ManpowerGroup

# Technology Competence Center



## OBBIETTIVI

Attraverso questa struttura **Experis** è in grado di proporsi come partner per la **Digital Transformation** per il settore della **Progettazione, Prototipazione, Supporto alla Produzione ed Innovazione Tecnologica**.

## Attività

- Virtual Validation:
  - ❑ Progettazione (**Computer Aided Design**) e Prototipazione Apparati Elettromeccanici e Strutture Meccaniche (**Digital Mockup**);
  - ❑ Progettazione (**Computer Aided Design**), Integrazione e Realizzazione Jig/Tool, Fixture, Attrezzature;
  - ❑ Analisi Termo-Strutturali (**Computer Aided Engineering**);
  - ❑ Analisi Fluidodinamiche (**Computational Fluid Dynamics**)
- Supporto alla produzione/industrializzazione (**Process Engineering, Data Management, Material Management, Work Flow**);
- Test/Qualifiche Enviromentali (**MIL-STD-810, RTCA-DO-160**);
- Innovazione Tecnologica & Tranfert Tecnologico (**Industry 4.0**)



# Technology Solution

## Tipologia Intervento

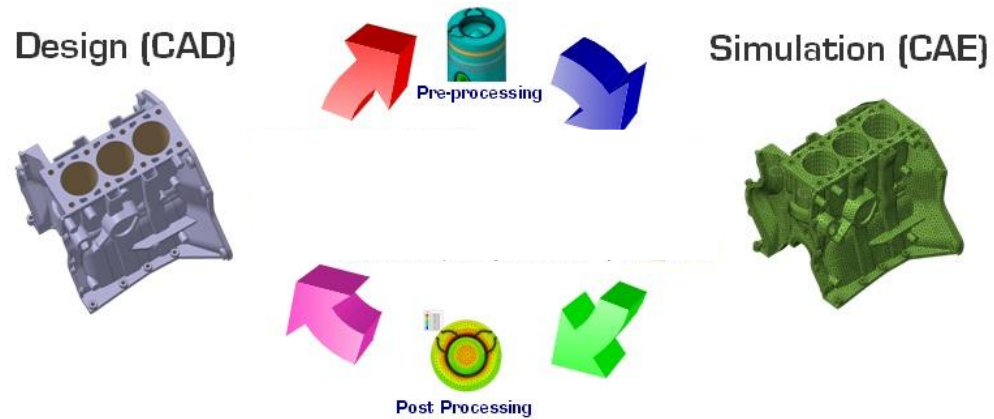

- Task Outsourcing completo :  
Postazione in sede;  
Workstation dedicate;  
Licenze Software dedicate;
- Task parziale presso cliente :  
Workstation dedicate;  
Licenze Software dedicate;

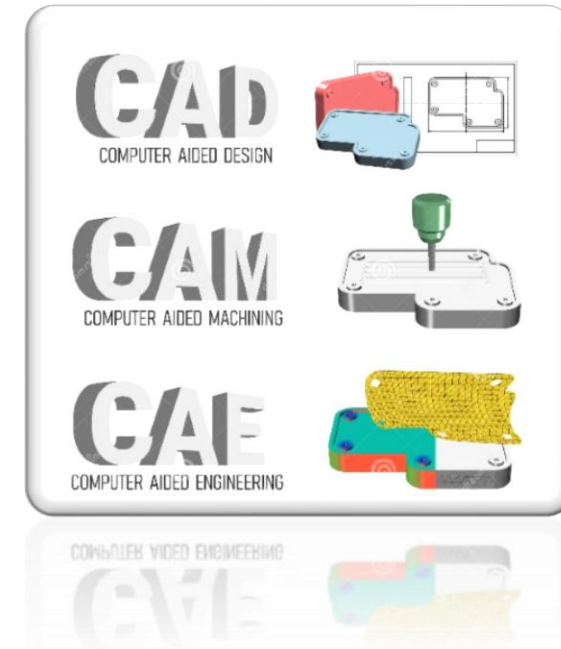

Sharing delle Competenze su differenti verticali di mercato ed applicazioni.

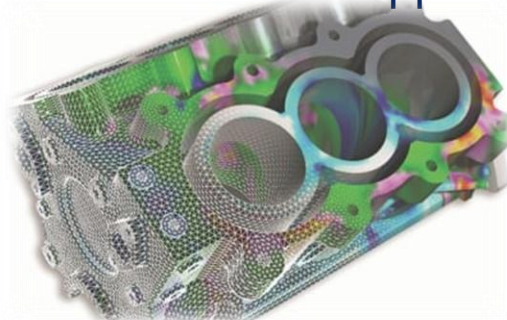

# Technology Solution



## DIGITAL CONTINUITY

# Technology Solution

## Competenze Industry 4.0

- **Advanced manufacturing solution:** sistemi avanzati di produzione;
- **Additive manufacturing:** sistemi di produzione additiva;
- **Realtà aumentata:** sistemi di visione con realtà aumentata;
- **Simulazioni:** simulazione tra macchine interconnesse per ottimizzare i processi.
- **Integrazione orizzontale e verticale:** integrazione e scambio di informazioni;
- **Industrial internet:** comunicazione tra elementi della produzione, Interni ed Esterni all'azienda.
- **Cloud:** implementazione di tutte le tecnologie in Cloud.

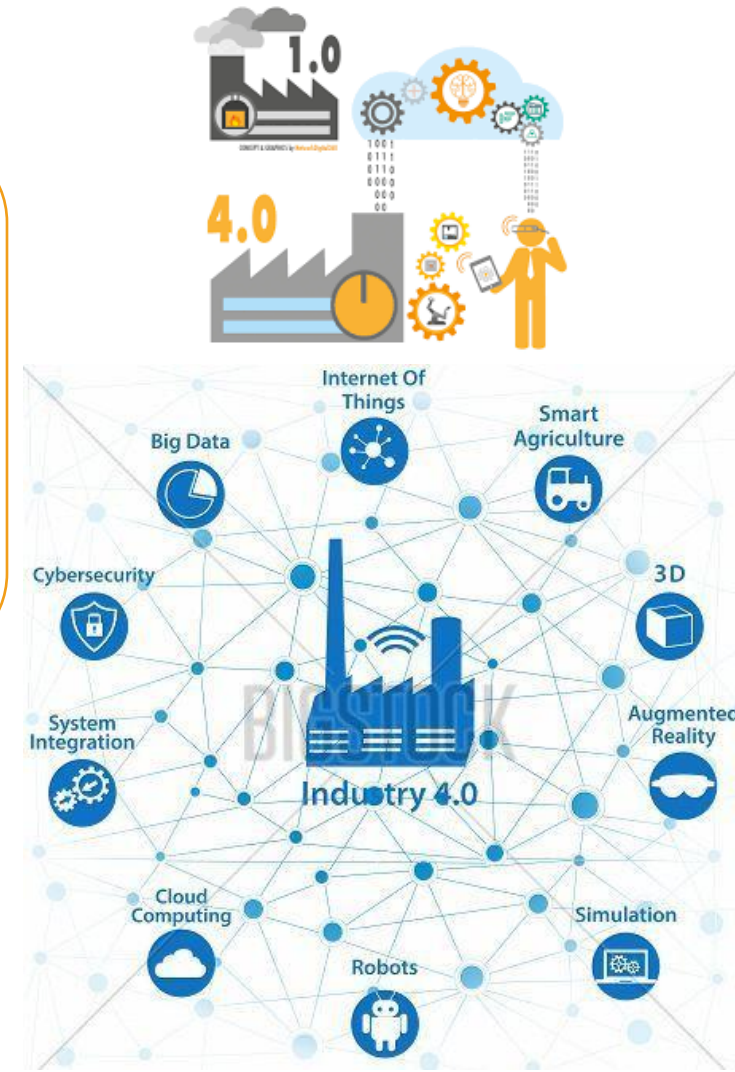

# Technology Solution – Delivery Model



## COMPETENCE CENTER

Team di competenze che operano sulla base di *KPI* o *SLA* relativi alla loro gestione o su base work packages.

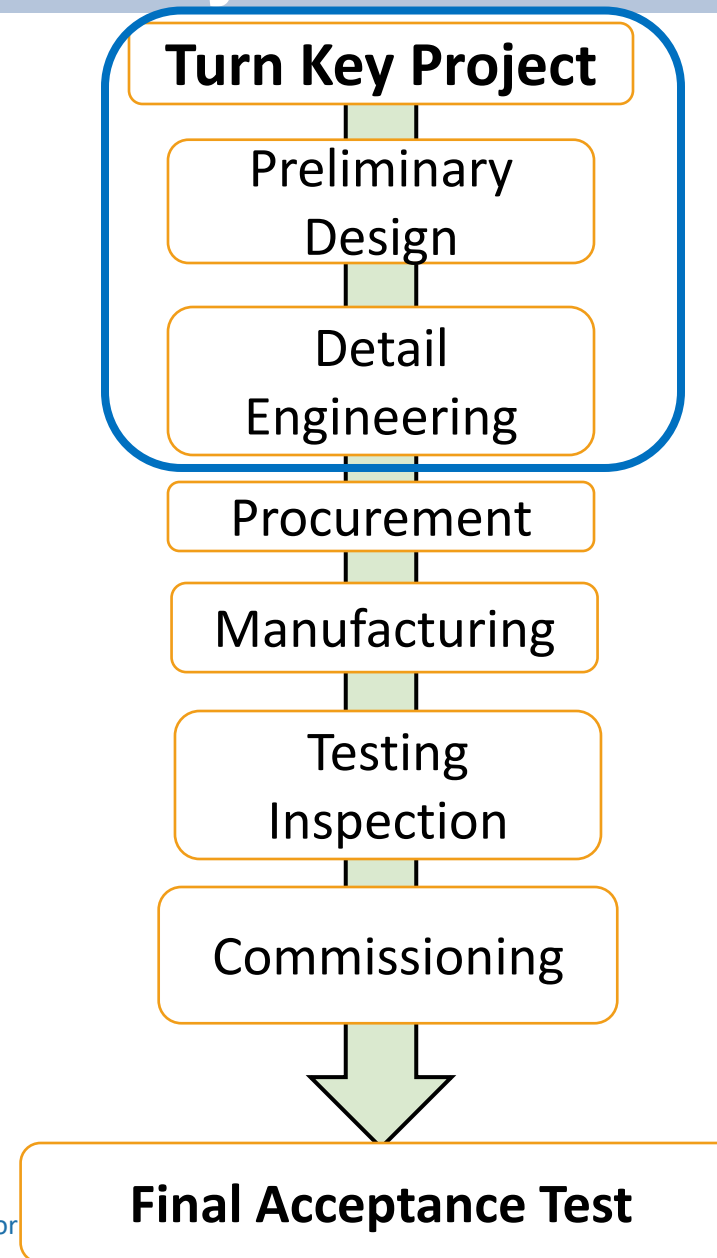

Project Management Activities

# Technology Solution

## Applicativi

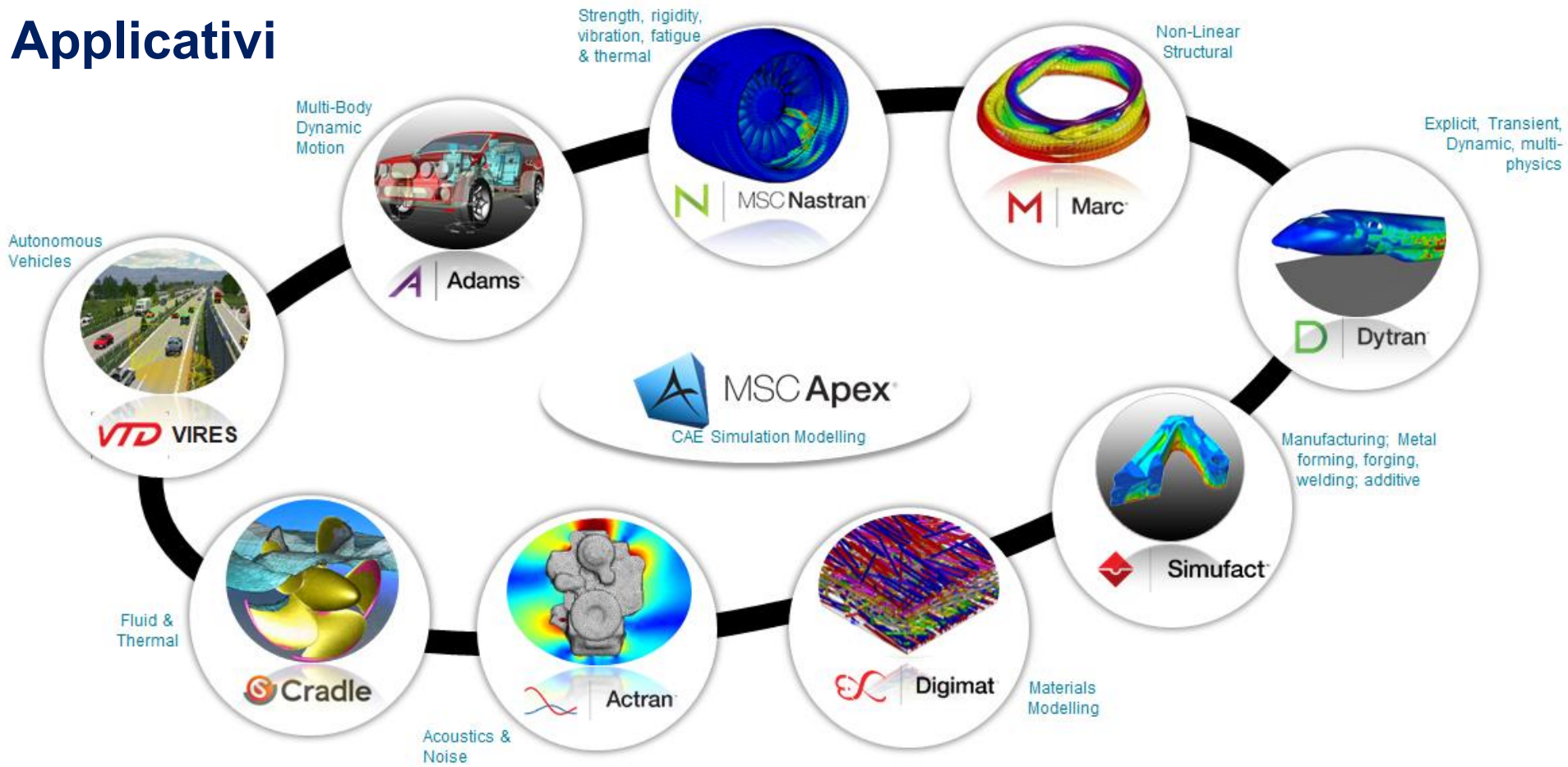

# Technology Solution – MECHANICAL PROJECT TEAM

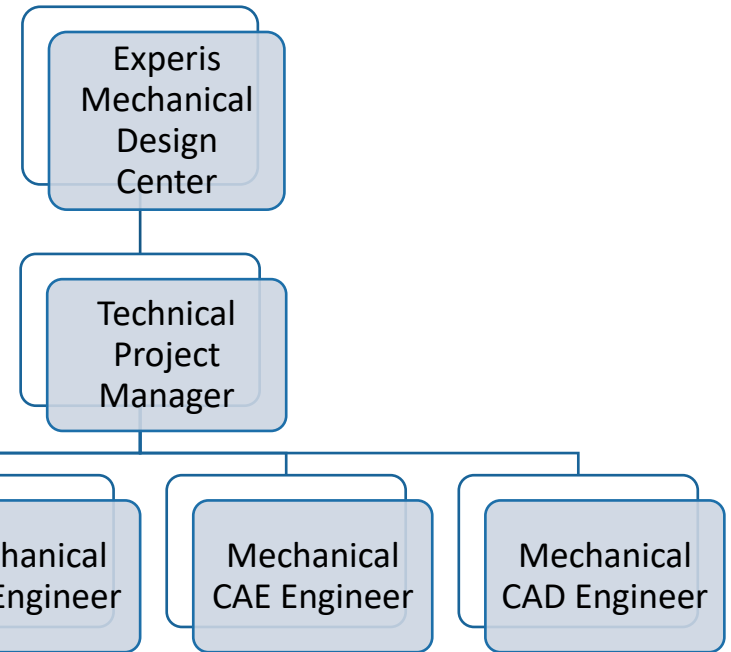

• **Attività:**

- Analisi Termo Strutturali;**
- Configuration Management;**
- Attività Turn-Key HW e Licenze Experis;**

• **Team dedicato al Progetto:**

- # 1 Team Leader Analista Termo Strutturale;**
- # 1 Progettista Meccanico CAD;**
- # 2-3 Analisti Termo Strutturali;**

*Il Team verrà coordinato e supporto dal Technical Project Manager*



Experis<sup>®</sup>  
ManpowerGroup

**SUCCESS CASE**

# Partnership

## 20 anni di impresa nel campo delle telecomunicazioni militari e civili

### ISO 9001:2008:2015

Sistemi di Gestione per la Qualità

### ISO 45001:2018

Sistemi di Gestione della Salute e della Sicurezza del Lavoro

### EN 9100

Sistema di gestione per la Qualità nel settore dello Spazio e della Difesa

### IPC/WHMA-A-620

Fabbricazione di cavi e cablaggi in ambito militare

Grazie alla partnership con **IcodeL** siamo in gradi di erogare servizi Turn-KEY nell'ambito della **Progettazione, Integrazione, Prototipazione (FAI) e Small Series.**



- Attestato di processo tecnologico , qualifica saldatura;
- Attestato di processo tecnologico , qualifica crimpatura;



# PROGETTO U212FNS – ICODEL / LEONARDO

## Contesto:

- Progettazione Elettro-Meccanica #Console per il programma U212NFS della MMI;

## Attività Principali:

- Progettazione e sviluppo CAD/CAE/CFD;
- Test di Qualifica;
- Industrializzazione;
- Supporto alla Produzione
- Manuale Assemblaggio e Manutenzione;
  
- Produzione
  - ✓ Radio Room Radio Console
  - ✓ Crypto Cabinet
  - ✓ Radio Cabinet EER

## Tecnologie:

MSC Apex/Patran/Nastran/Cradel, PTC CREO;  
UNI EN 9100; MIL-STD 810 ; RTCA-DO160

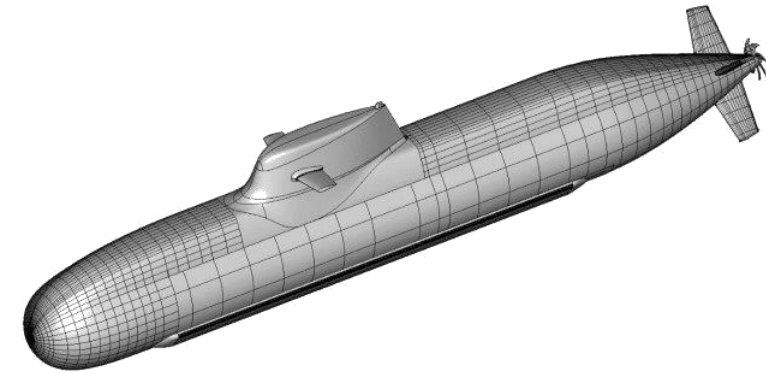

# PROGETTO U212FNS – ICODEL / LEONARDO

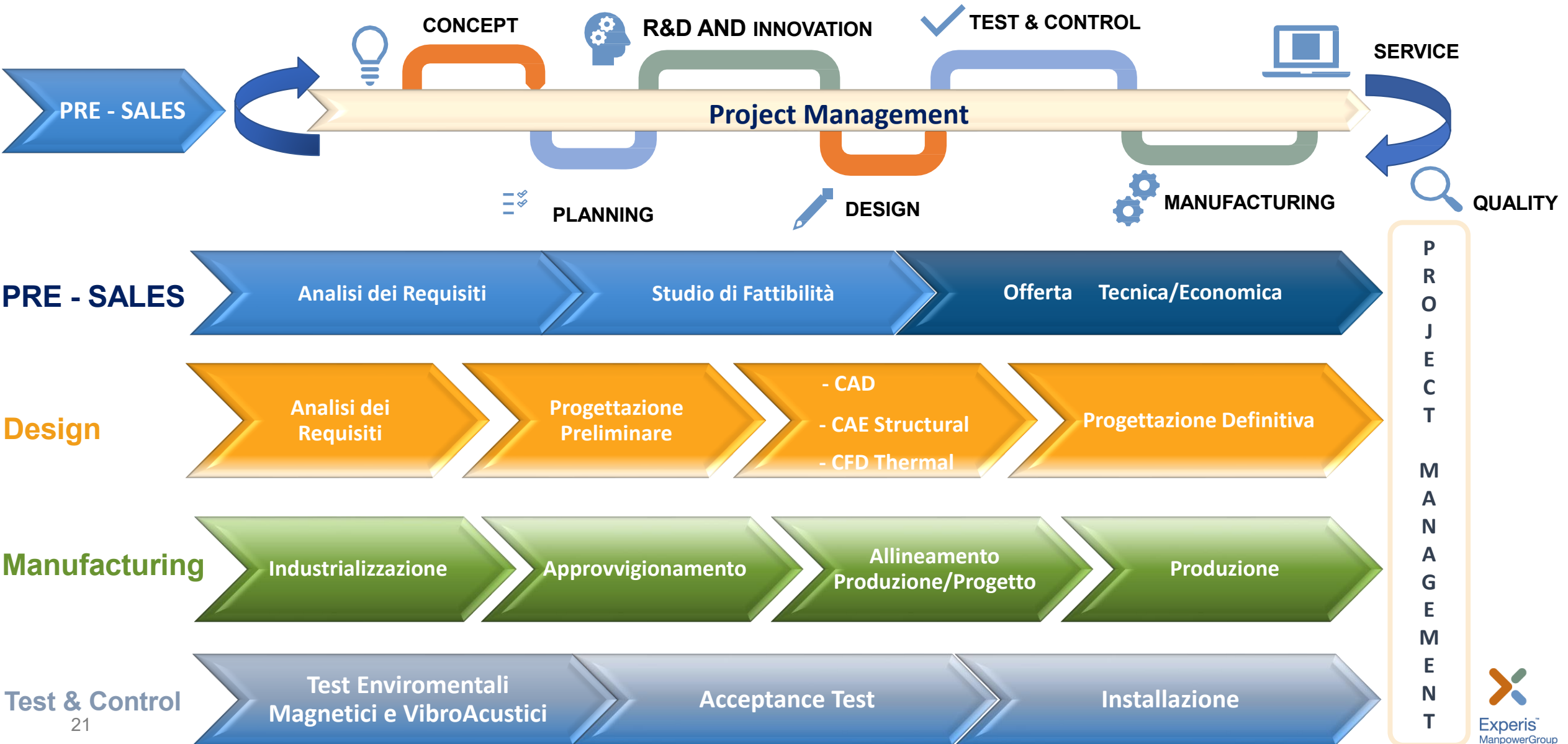



# Structural Analysis

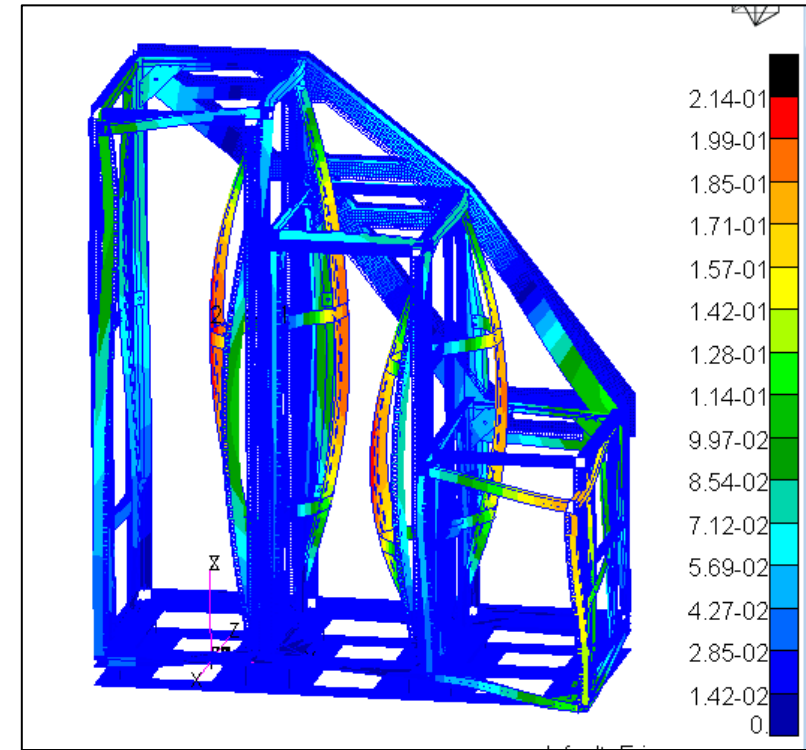
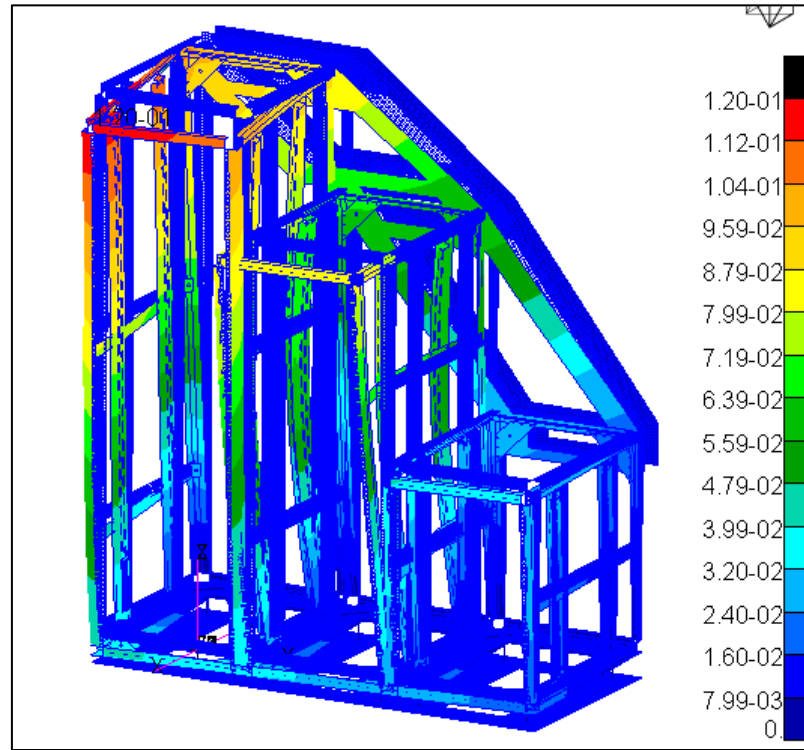
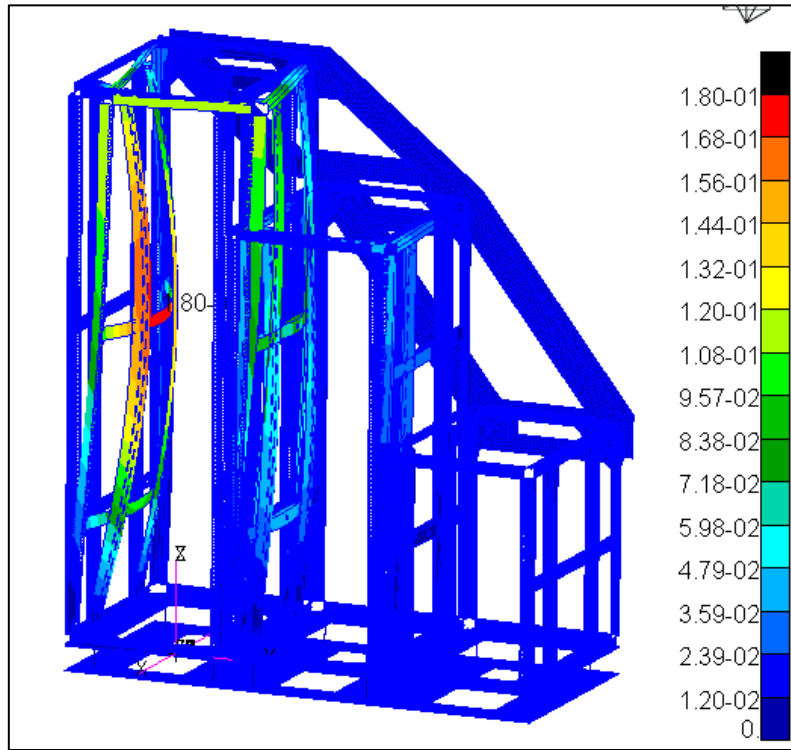

FREQ	T1	T2	T3	R1	R2	R3
6,83	39%	0%	0%	0%	7%	40%
9,93	7%	1%	4%	4%	2%	4%
10,57	2%	8%	41%	42%	0%	0%
17,97	1%	2%	3%	0%	15%	4%
29,01	0%	56%	7%	29%	1%	3%
42,41	0%	4%	2%	2%	3%	8%
116,66	0%	5%	0%	1%	0%	2%
663,56	0%	0%	0%	0%	0%	0%
<b>SUM</b>	<b>82%</b>	<b>91%</b>	<b>86%</b>	<b>93%</b>	<b>76%</b>	<b>86%</b>

# Thermal Analysis

## CFD Analysis – MSC CRADLE TOOL

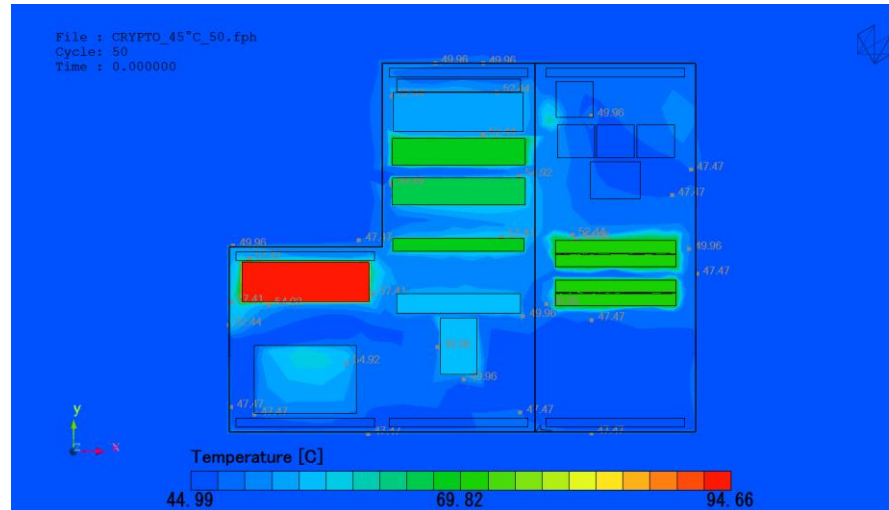
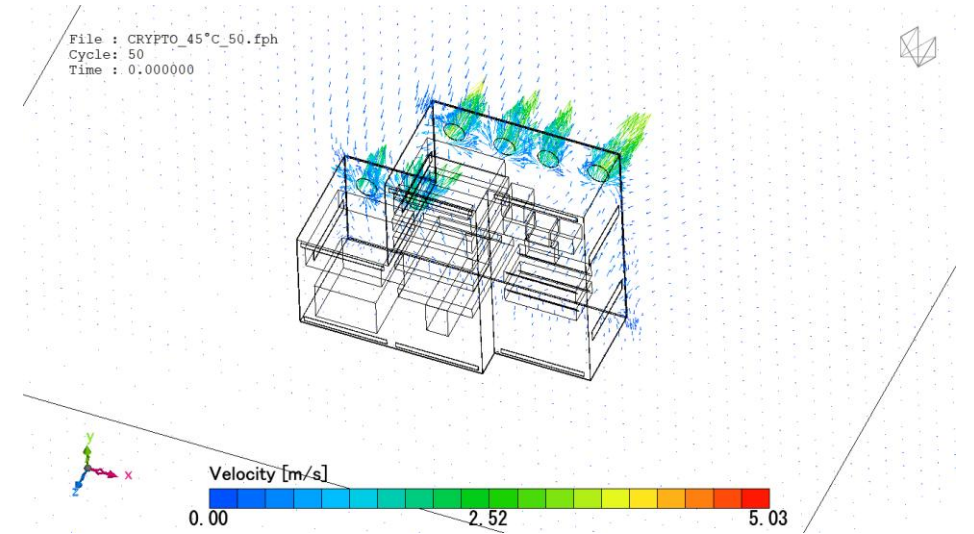
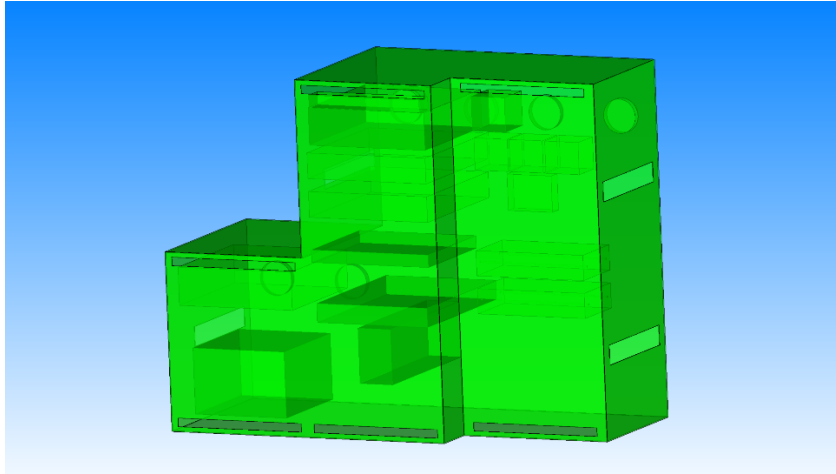

# Power Distribution Unit Detail Electro Mechanical Design

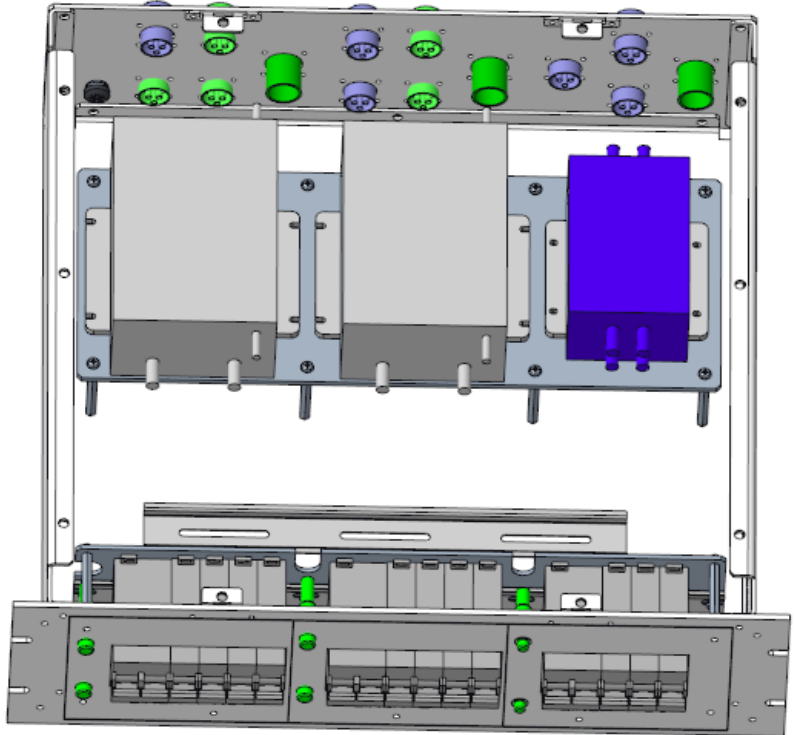
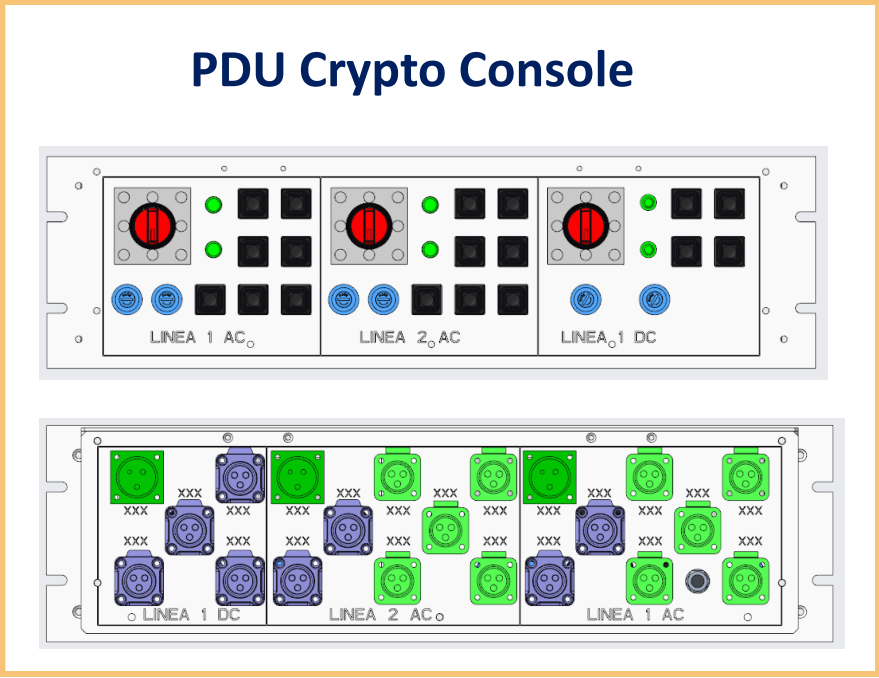
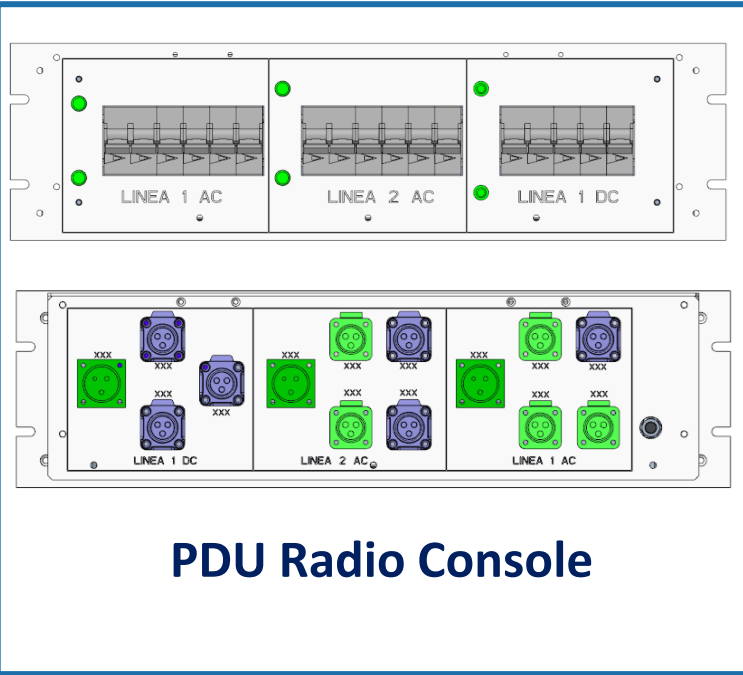

# PROGETTO U212FNS – ICODEL / LEONARDO

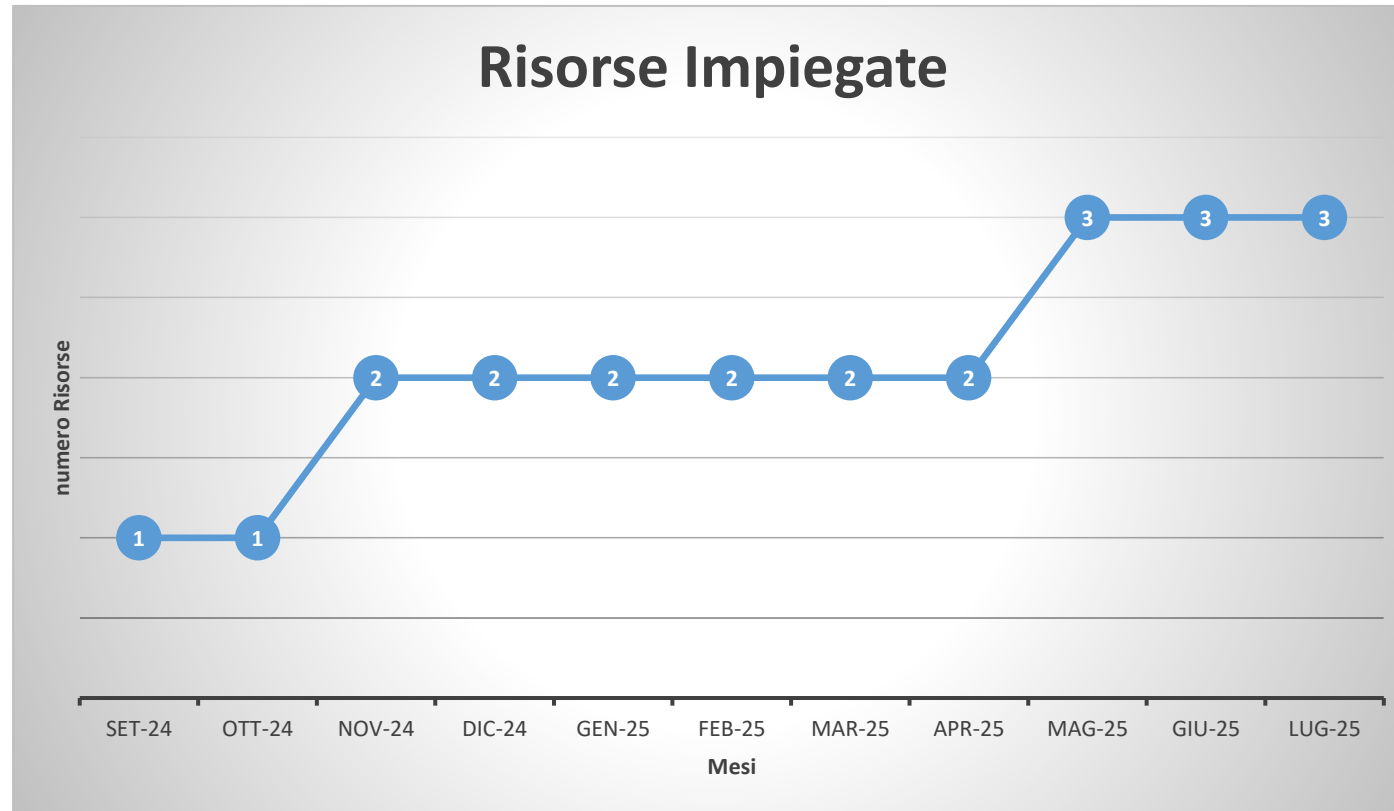

**Team 5 Risorse**

Than 

**Marrocco Giuseppe**  
***Business Development Manager***  
**Experis**

**Mob.: +39 344 047 02 53**

**email: [giuseppe.marrocco@it.experis.com](mailto:giuseppe.marrocco@it.experis.com)**

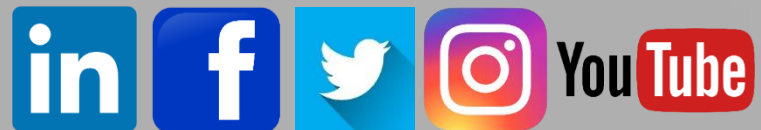

[www.experis.it](http://www.experis.it)