



*TOGETHER  
WE FLY  
IN CLEAN SKY*

# Who we are

## Company Overview

### OMI – OFFICINE MECCANICHE IRPINE

#### Innovation and Sustainability at the Service of People and Planet.

- Since 1983, Officine Meccaniche Irpine (OMI) has been operating for over 40 years in the aerospace and defense sector with both national and foreign clients mainly in Europe and America. OMI boasts a consolidated relationship of collaboration with the main sector's Prime Contractors, including Leonardo, Boeing, Airbus and Lockheed Martin, as a supplier of large, complex airframe and aircraft support equipment.
- OMI offers a complete technological offer of services and products including design and development, production, surface treatments, qualifications and functional tests. Thanks to technologies and proprietary products developed, and to certifications obtained in aeronautical and defense sectors, OMI is proposed as GLOBAL TIER 1 PARTNER.
- OMI participates in the "Leonardo Empowering Advanced Partnership" LEAP program, aimed to support the sustainable growth of companies enabling to compete on the national and international market. In 2021 OMI received from Leonardo the Operational Excellence Award as best Partner per performance.
- In the last three years OMI has launched an important product diversification initiative by entering the OIL&GAS and Space fields.
- Always attentive to EGS principles, OMI was certified in 2022 in accordance with PDR 125:2022 for Gender Equality and since 2020 has published the Sustainability Manifesto annually.

#### OMI VALUES:

- ONE VISION
- EMPATHY
- TOGETHERNESS
- RESPONSIBLE DECISION MAKING
- GENDER EQUALITY IN OUR DNA



# Company Overview



## Revenue (2025):

- 18 M€ (Draft)



## Employees (2025):

- 87 OMI + 28 LFI



## Industrial Sectors:

- Aerospace, Defence, Space
- Automotive, Oil&Gas, Naval
- Unmanned aerial vehicle



## Square meters:

- 22.500



## Location:

- Lacedonia (Avellino) Italy
- Vallata (Avellino) Italy



## Reduction:

- 25% of annual energy consumption

## Staff censuses

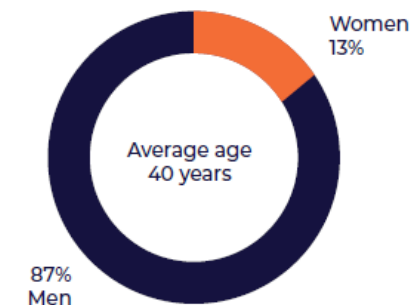
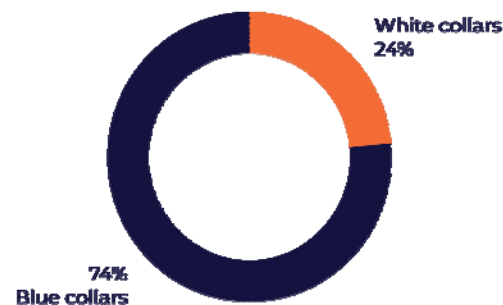

# Location - Plants

## OMI is located in Lacedonia and Vallata (Avellino, South Italy)



### HQ Lacedonia Plant – 6,500 sqm

3-axis and 5-axis Machining and turning of structural parts, long up to 14 mt in several type of metall alloys. Contouring of composite materials, Dimensional Controls, welding and Assembly

### Vallata Plant 1 – 7,000 sqm

5-axis Machining and turning of structural parts, NDI & surface treatments of titanium, Painting plant both for aeronautical and general application

### Vallata Plant 2 – 7,000 sqm

Composite Materials Hand Lay-up, Autoclave's Cure, CN Contouring



# OMI - Organization

OMI Board of Directors:

BoD's Chairman: Aquilino Carlo Villano

CEO: (R&D, Production, Purchasing, Commercial): Andrea Villano

Executive Deputy Chairman (Finance, Compliance, Sustainability, Humane Resource): Maria Grazia Villano

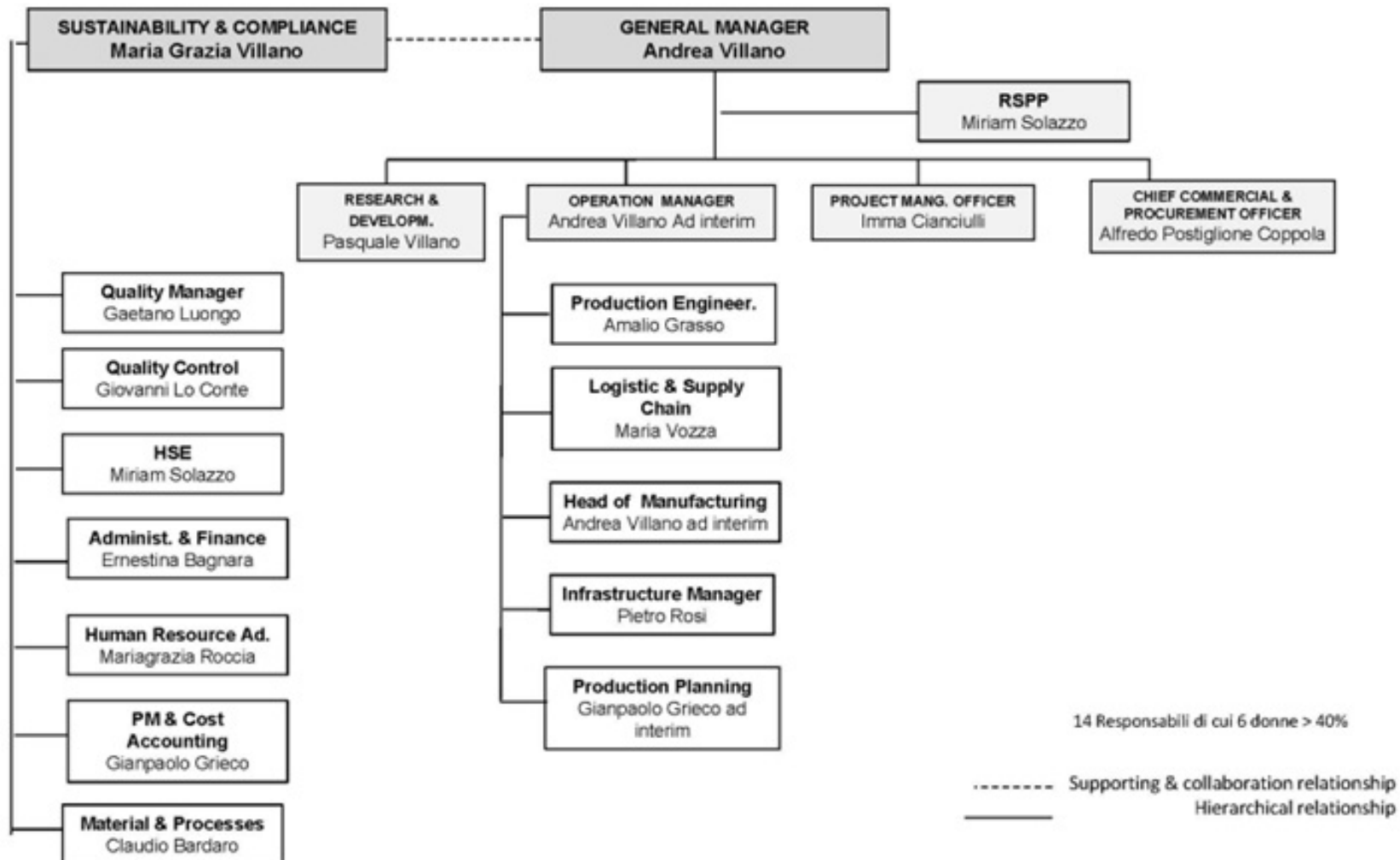

# Aerospace Programs

## PROGRAMS ACTIVITIES:

Design off load;  
Tooling;  
Manufacturing;  
Certification Support;

OMI is involved in several kind of activities for military and civil aircrafts. The line of business is principally splitted in two:

- Manufacturing with customer design authority of flying parts;
- Design and manufacturing of tools for production activities like:
  - Milling fixture;
  - Hand/ Automated layup tools;
  - Assembly, Handling & Transportation jig.

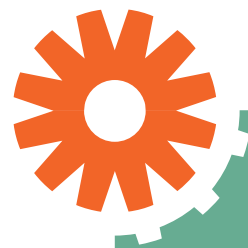

# Certifications & Approvals

## INTERNATIONAL STANDARDS

- UNI EN 9100:2018
- UNI EN ISO 14001:2004
- NADCAP NonDestructive Testing (plant 1 Vallata)
- NADCAP Chemical Processing
- AWS D1.1 (Structural Welding – Steel)
- ASME BPVC Section IX (Welding and Brazing Qualifications)
- PDR 125:2022 (Gender equality) ASME IX Process 141GTAW

## BOEING

- BAC5665 (Application of Sol-Gel Conversion Coatings on Corrosion Resistant Alloys for Painting (Approval required for Spray, Manual and Immersion application excluding touch up due to post application operations)
- BAC5423 (Penetrant Inspection)
- BSS 7039 (Liquid Penetrant Inspection)
- BAC5753 (Cleaning - Descaling of Titanium – Method II Only)
- Chemical Testing (Process Solution Control)
- NAS410 (NDI Personnel Certification Level 3 Penetrant)

## LEONARDO

- NTA81351-1 (Installation of Bushings, Press and Shrinking and/or Expansion Fit)
- NTA81351-2 (Bearing Installation and Retention)
- NTA94551 (Electrical Conductivity Inspection of Aluminum Alloy)
- DPD: QUALITY ASSURANCE STANDARD FOR DIGITAL PRODUCT DEFINITION
- NTA 95051 (Hardness Test)
- BAC5325, BAC5710, BAC 5845 (Coating Application for Boeing Programs)

## BAKER HUGHES (OIL&GAS)

- L6620 machining process
- S0601 SMAW Welding
- OGQ-461350-MPP.

## AIRBUS

- ADET0030 (Structural bolt tightening torques)
- ADET0059 (Inspection of permanent and removable fasteners after installation)
- ADET0187 (Wet installation of fasteners)
- ADET0025 (Process fasteners installation on uncured interfacial sealant)
- ADET0033 (bonding of bushes, ball bearings and spherical bearings)
- ADET0082 (Application of sealant)
- AIPS03-03-012 (Installation of bearing, spherical bearing and bushes by swaging)
- ADET0029 (installation of cylindrical shear bolts)
- ADET0078 (structural riveting)
- ADET0173 (installation of tight fit bushes)
- ADET0191 (installation of ball bearing, spherical bearing and bushing by staking)
- 80-T-34-3050 (Tightening of Screws and Nuts)
- 80-T-34-3001 (Installation of Fasteners and Nuts)
- IGC04-25-120 (instructions for inspections by electrical conductivity – eddy currents)

## LOCKHEED MARTIN

- LMA-PG001 (Pre-Penetrant Etch – Titanium)- Coating)
- LMA-PJ264 (application and control of organic finishes)
- LMA-PJ013 (Touch up requirements for chemical and organic finishes)
- LMA-PC201(Penetrant Inspection Fracture Critical)
- LMA-PC201(Penetrant (Fluorescent) Inspection)
- PC003 (Penetrant Inspection acceptance Criteria)
- MIL-C-27725/AMS-C-27725 (Fuel Tank Coating)
- MIL-STD-6866/ASTM-E-1417 (Penetrant Inspection)
- LMA PH016-Titanium Conversion Coating
- LMA PC009-Hardness Testing NonDestructive Methods
- LMA PK004 (Installation Procedure for Bonded Nutplates)
- PB033 (Installing, sealing, and coating of bearings chilled to sub-zero temperatures)
- LMAPB029 (installation of expanded bushings in metallic structures)

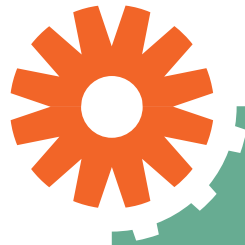

# OMI's Customers

## AEROSPACE



LOCKHEED MARTIN



BOEING



LEONARDO

HELICOPTERS



LEONARDO

AEROSTRUCTURES



LEONARDO

AIRCRAFT



VODICHODY

AIRBUS

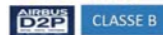

CLASSE B



AVIO

## OIL&GAS

Baker Hughes 

## AUTOMOTIVE



## OTHER FIELDS



# Technologies

## MACHINING

- 24 Milling Centers 3/4/5 Axis
- 2 Turning Centers
- Machining of titanium, steels, aluminum, composites
- Large Dimensions Parts Machining
- 3 shift/day

## WELDING

- Carbon Steel/ Stainless Steel / INVAR
- Aluminum

## TOOLING

- Design
- Manufacturing
- Inspection and Testing

## ASSEMBLY

- Primary and Secondary Structures
- Riveting, Bushing and Bearing Installation

## INSPECTION AND TESTING

- NDI, Ultrasonic Inspection
- NDI, Penetrant Inspection
- CMM Machines for 3D Dimensional
- Laser Tracker and Laser Scanner Inspection
- Mechanical/Structural Testing
- Electronic Testing

## ENGINEERING

- Aerodynamics
- Aircraft Performance and Design
- Analysis (Structural and Fluidynamics)
- System Design and Testing-Tool Design
- R&D Department

## SURFACE TREATMENTS AND PAINTING

- NDI
- sand blasting
- Conversion Coating of Titanium
- Coating Applications
- Painting

## COMPOSITES

- 1500 sqm Clean Room
- 2 x Autoclave up to 7.5 mt
- CNC Contouring
- Pre-preg Layup
- Infusion Processing
- R.F.I. &L.F.I.
- C-Scan Inspection (CNC Controlled)
- Testing Laboratory

## CERTIFICATION SUPPORT

- DOA/POA Certification
- Composite Allowables and Fatigue
- Test Plan and Test Reporting

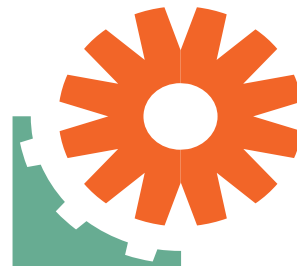

## OMI ENGINEERING DEPARTMENT

Mission: to meet the needs of several Customers with innovative solutions

### SERVICES:

- Advanced design (CAD)
- Configuration Management
- Numerical analysis
- Stress analysis
- Certification support

### OPERATIONAL SECTORS:

- Aerostructures
- Mechanical/Electrical Systems
- Avionics
- Kinetic Modeling
- Software: CATIA V5, AUTOCAD, UNIGRAPHICS, PLM, HYPERMILL

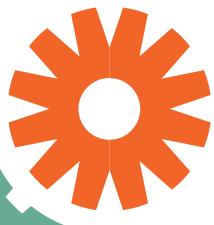
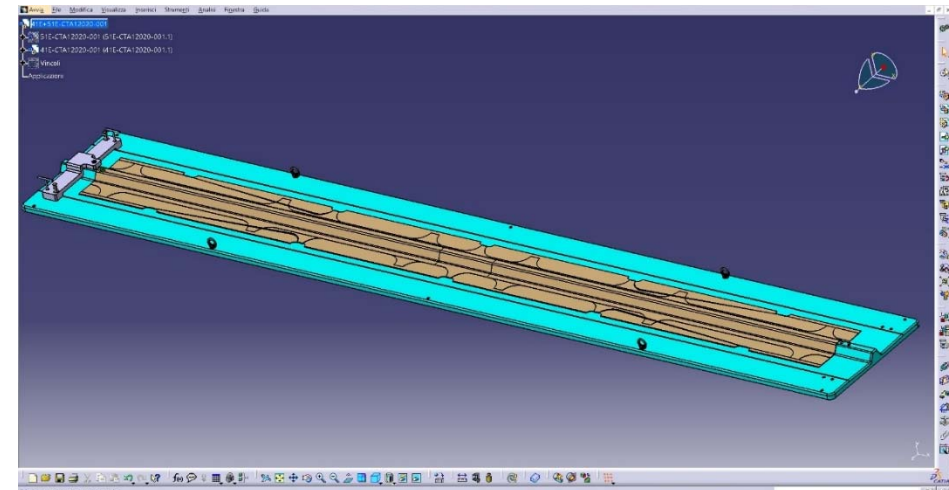
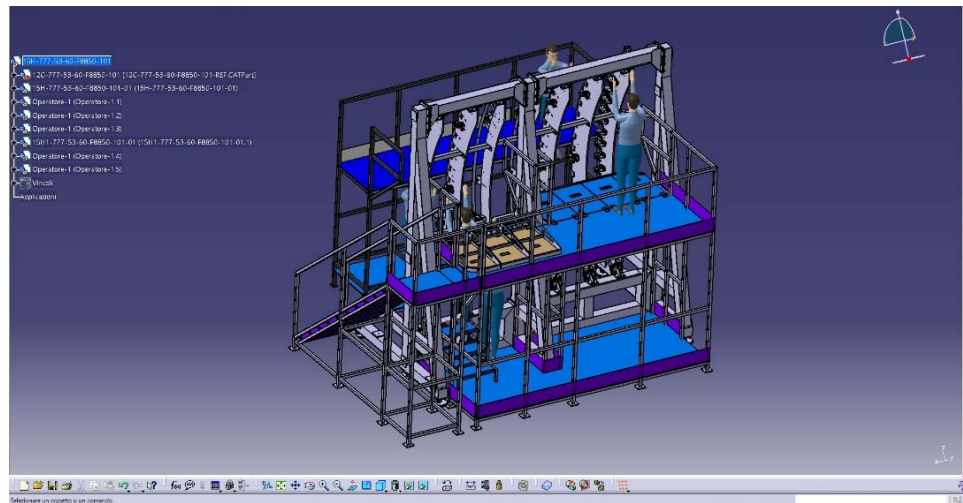
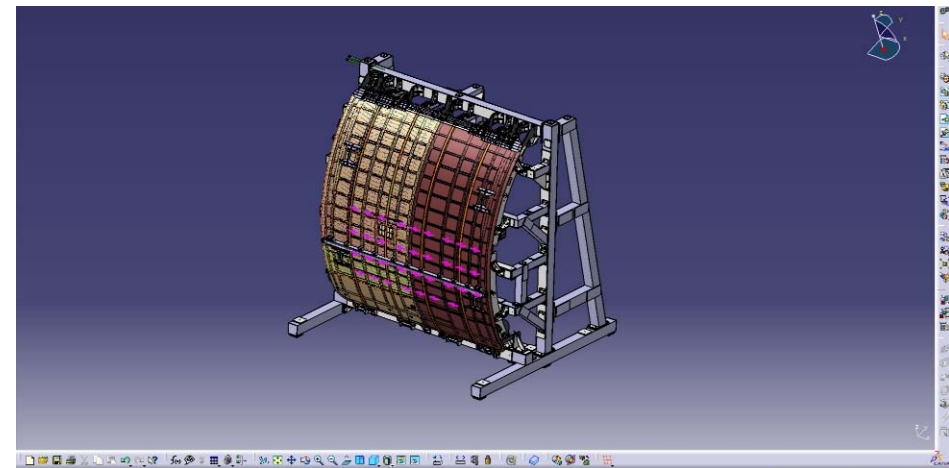

# Technologies

## Inspection & Testing

- NDI, Ultrasonic Inspection
- NDI, Penetrant Inspection
- CMM Machines for Dimensional Inspection (up to 8 mt)
- Laser Tracker and Laser Scanner
- Mechanical /Structural Testing
- Tool Room (Presetting and Balancing)
- Mechanical Testing



## Surface Treatments & Painting

### ST & Painting Plant Main characteristics

- Tanks' size: 6.5 mt x 2.5 mt x 1.1 mt
- Paperless plant (PLC management)
- Painting box's size: 9 mt x 5 mt x 4 mt
- Double oven (Primary & Secondary)

### Processes

- Sand Blasting
- NDI Liquid Penetrant Inspection
- Ti Conversion Coating
- Ti Paint Applications
- General Paint Application

### FULLY REACH COMPLIANT PLANT



Load



Etching and Conversion Coating



NDI



Final Inspection



Automated Painting Line



Chemical Laboratory

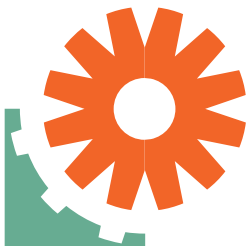

\*\*\*\*\*  
Planned installation of Aluminum ST plant  
\*\*\*\*\*

# Internal production volume & supply chain

Part numbers	Annual production
4957	Over 50.000 parts

## PRODUCTION REVENUE

39% military  
60% civil

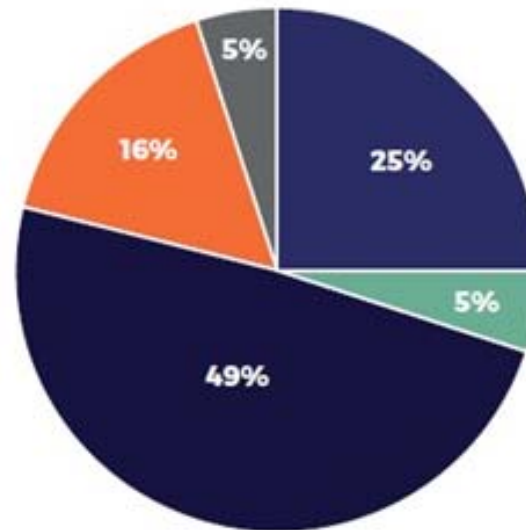

- (49%) AEROSPACE PRODUCTION - (LEONARDO)
- (16%) AEROSPACE PRODUCTION - (Other customers)
- (25%) OIL&GAS PRODUCTION
- (5%) AUTOMOTIVE PRODUCTION
- (5%) GENERAL MECHANICS

## Supply chain

OMI boasts a strong and crucial supply chain especially in the area of heat and surface treatments, special processes that directly influence the quality and durability of products; but it also plays a key role in the mechanical machining of parts by adding additional capabilities to our current one. thanks to its supply chain OMI covers almost all the critical and special processes.



# Products

## F35 – Titanium Bulkheads

OMI is the sole European supplier of the two titanium bulkheads, the critical primary structures of the F-35. OMI imports the raw material directly from the U.S. (Drop Shipment), performs the machining (buy to fly >95%), surface treatments and subassemblies, delivering the parts directly to the Italian FACO (Final Assembly and Check Out) in Cameri (NO).



# Products

## Boeing 777 - Assembly JIG Reconversion

DESIGN, CRITICAL DESIGN REVIEW, MANUFACTURING (MILLING & TURNING), DIMENSIONAL CONTROL AND ASSEMBLY OF EACH JIG

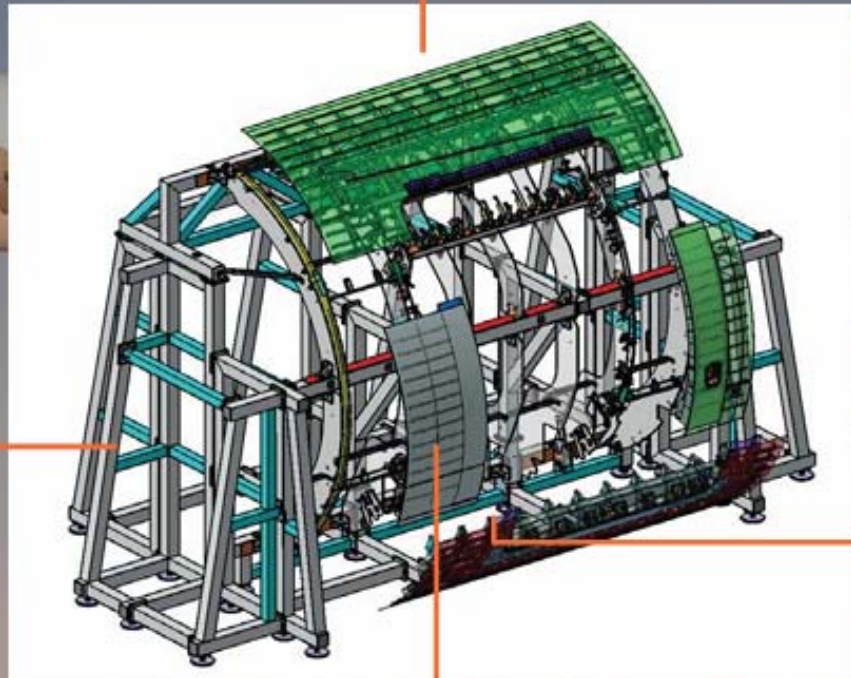

TOP-SURROUND



UPR-SURROUND  
Dim 8.500x4.000x4.500



AFT-FWD-SURROUND  
Dim 4.000x4.000x4.500



LWR-SURROUND  
Dim 8.500x4.000x4.500

# Products

**COMAC Program.**

**Tool dimensions 2.600x15.600mm:**

*MILLING A 15.6-METER TOOL  
DIVIDING MILLING ACTIVITIES INTO TWO HALVES USING LIFTING CRANES*



# Products

**EUROPEAN-EXTREMELY LARGE TELESCOPE**

**Final Customer: E.S.O.**

**General Contractor: CIMOLAI s.p.a.**

*ALTITUDE GUIDES of E.L.T. MACHINING & JOINTS*

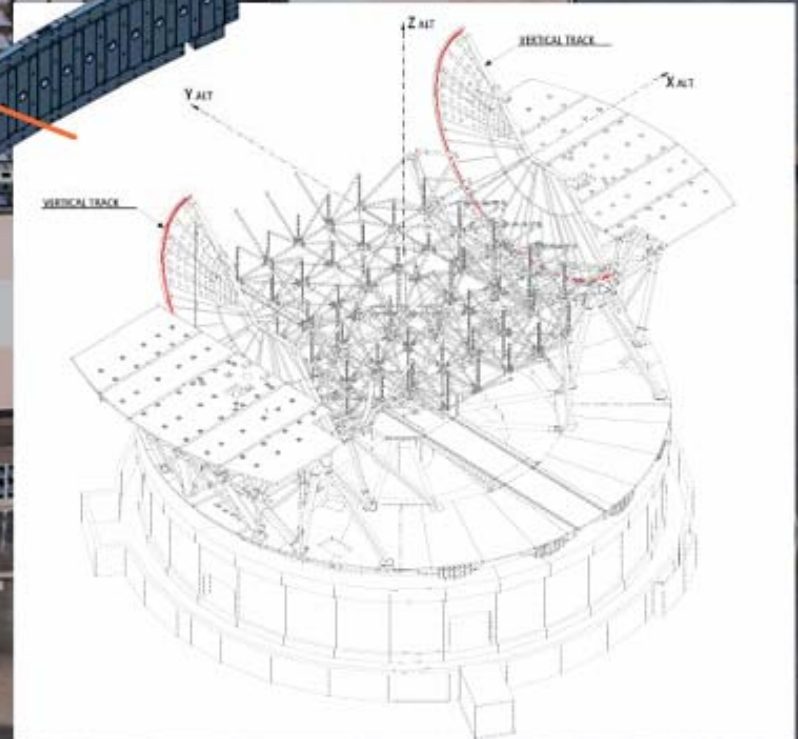
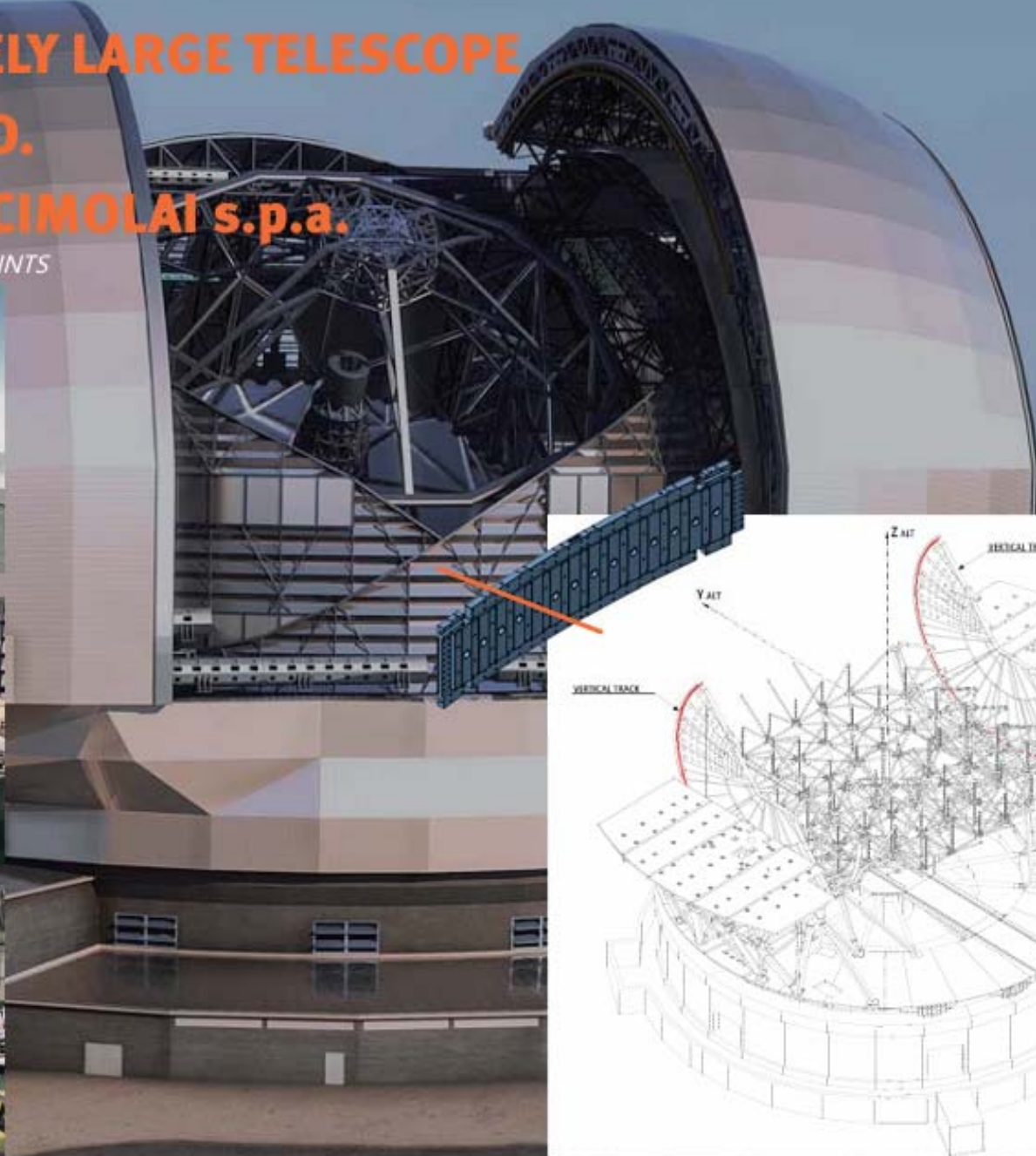

# Products

## ACTIVITIES:

**CARBON-FIBER COMPOSITE DISKS  
AND CYLINDERS INDUSTRIALIZATION,  
MANUFACTURING, QUALITY CONTROLS  
AND DELIVERY @CERN**

*CARBON FIBER STRUCTURE COMPOSED BY 8 DISKS AND 6 CYLINDERS  
MANUFACTURED WITH HONEYCOMB SANDWICH STRUCTURE.*



*The TB2S Wheel is 2.4 m long  
and 2.3m in diameter*



# Products

## R&D PROJECT

*NEXT GEN CTR ROTOCRAFT WING  
and Nacelle manufacturing & final  
assembly*

*OMI designed and produced all the tools in  
order to manufacture and to assembly the  
parts of the wing*

*UPR WING Mould tools WING JIG*

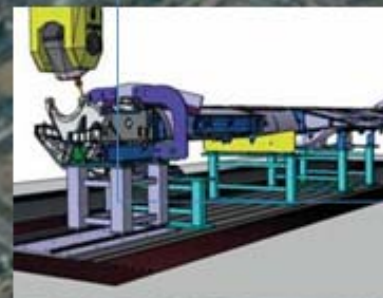

# Products

**ACTIVITIES:  
CARBON STEEL MACHINING FOR  
CENTRIFUGAL COMPRESSORS**

(Oil&Gas Field):



*Cushion case*



*Diaphragms*



*Valves*



*Pumps*



# Products



## Avio – Space Product

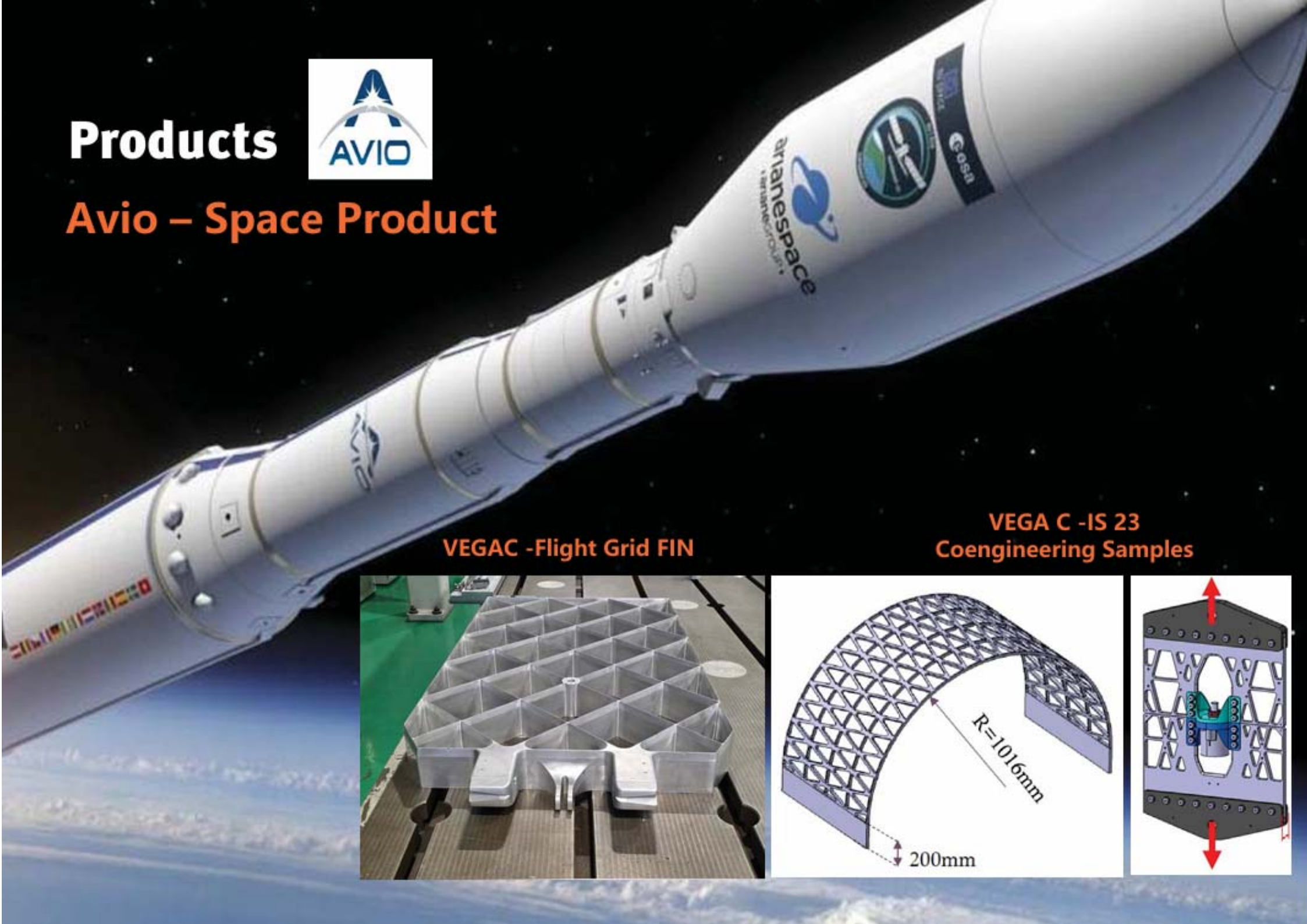

VEGAC -Flight Grid FIN



VEGA C -IS 23  
Coengineering Samples

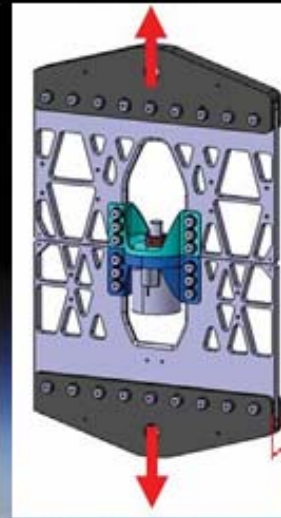
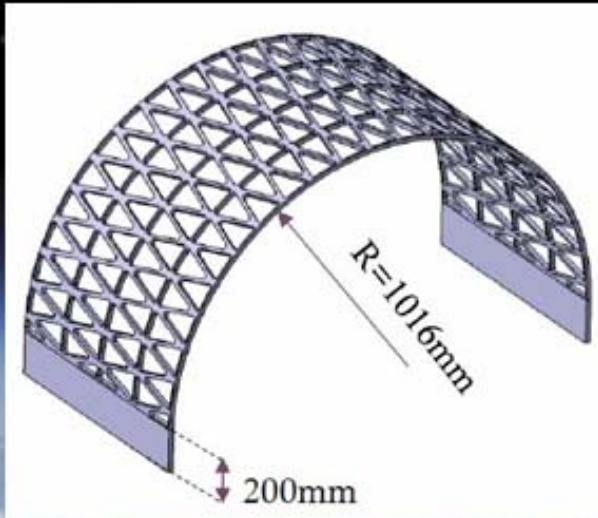

# Gender Equality and Sustainability Rating



THE PROJECT INVOLVES THE INVOLVEMENT OF DIFFERENT BUSINESS STAKEHOLDERS FOR PROMOTING GENDER EQUALITY AND WOMEN'S EMPOWERMENT IN THE TERRITORY



## SUCCESS MEASURES FOR GENDER EQUALITY

KPI	Actual (2025)	Goal (2030)
% Women	13%	> 20%
Gender Pay Gap	0%	0%
% Women Manager	40%	> 40%
Diversity of Member of Board	33% Women	> 30% Women

The Gender Equality Management System is certified in accordance with PDR 125:2022

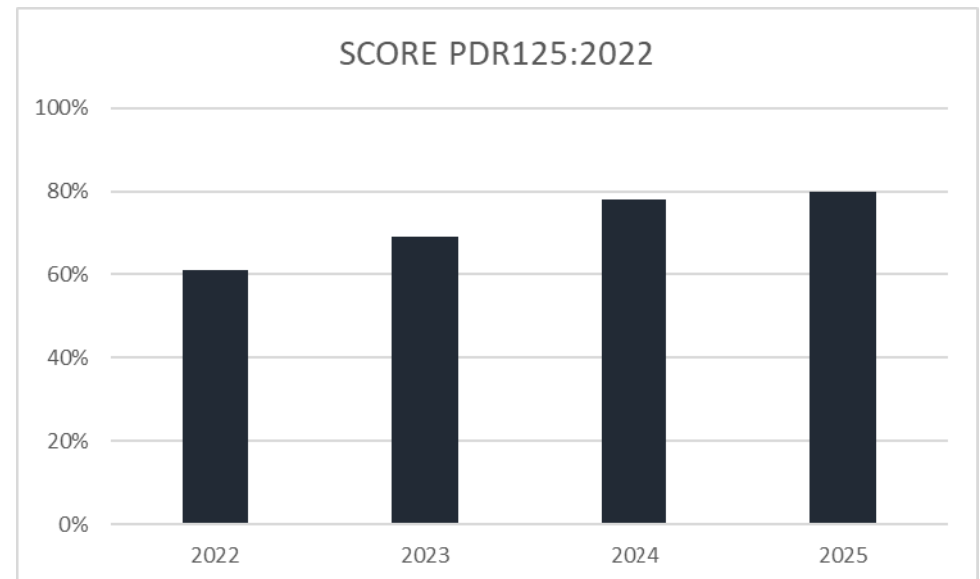

**Thank you for your attention**



**[www.omi.aero](http://www.omi.aero)**

***TOGETHER WE FLY IN CLEAN SKY***